

www.relync.com



R1
Electric Mobility Scooter
Owner's Manual
Model: RAA

WARNING: Please read the user manual before operating this scooter

Relync Tech LTD.
Version :EN032019REL

The Art Of **Mobility**



**Thank you for your purchase and
welcome to Relync Tech!**

Relync Tech Ltd has employed the most advanced technology available to create a revolutionary new mobility scooter offering improved safety as well as comfort and convenience. The Relync R1 has been designed to give users the ability to become mobile with confidence. Relync continues to strive to improve automation with the aim of revolutionising the whole industry.

Content

I. INTRODUCTION	4
Background	4
Indications for Use	5
Intended Users	6
Certification and Compliance	7
II. SAFETY	8
General	8
Modifications	11
Pre-ride Safety Check	11
Weight Limitations	12
Tyre Inflation	12
Incline	13
Cornering	17
Braking	17
Driving Surfaces	18
Stationary Obstacles (steps, kerbs, etc.)	18
Inclement Weather Precautions	19
Freewheel Mode	19

Batteries and Charger	20
Motor Vehicle Transport	21
Medical Conditions	21
Product Safety Symbols	22
EMI	23
III. PRODUCT DESCRIPTION	25
Basic Principle	25
Dimensions	25
Specifications	26
IV. YOUR RELYNC R1	28
Driving Console	28
Display	29
Scooter	30
V. OPERATION	31
Unfolding Your Relync R1	31
Folding Your Relync R1	36
Getting on Relync R1	39
Getting off Relync R1	39
Driving	40
Switching on Relync R1	40

Forward Driving -----	41
Reverse Driving -----	41
Stopping -----	42
Emergency Braking -----	42
Steering -----	42
Operating the Freewheel Mode -----	43
Batteries and Charger -----	44
Installing and Removing the Batteries -----	45
Charging the Batteries -----	46
Charging Indication -----	47
VI. TROUBLESHOOTING RELYNC R1 -----	48
VII. MAINTENANCE -----	49
Wheels and Tyres -----	50
Batteries and Charging -----	50
Cleaning, Body Care -----	51
Storage -----	51
Disposal -----	52
VIII. LIMITED WARRANTY -----	53
IX. TRANSPORTATION -----	55
X. CONTACT INFORMATION -----	56

INTRODUCTION

Background

Designed to be used indoors as well as on pavements, the Relync R1 Class A mobility scooter features the latest advanced technology. When being used on pavements, due care must be paid to pedestrians who should be given priority and, while consideration should be shown to all pavement users, pedestrians with impaired hearing or eyesight should be paid particular attention since they may not be aware of your presence.

As a general rule and in the majority of countries, only the disabled are permitted to use a mobility scooter. Those with the inability to walk any distance without aid are classed as disabled for this purpose, for example the elderly, the physically disabled or those suffering from an injury or long term medical condition. The exceptions to this are when the scooter is being demonstrated for sales or training purposes or when it is being transported to a repair facility.

For purchasers who have not used a mobility scooter before or for those who have not used one for some time, it is advisable to arrange training to gain full confidence in the steering, control and operation of the scooter and, whether or not you have driven a motor vehicle before, it is also important to maintain a good standard of driving skills. Training should also assess other important elements such as eyesight, the ability to concentrate and react, balance, the safest and easiest way to get on and off the scooter, posture when seated and the ability to sit in that position for sustained periods of time. Whilst an eyesight

test is not required in order to use a mobility scooter, it is essential that the user has a good standard of vision. Please bear in mind that vision does generally deteriorate with age and therefore regular eye tests are recommended. If poor eyesight leads to an accident, then you could become liable to pay compensation to any injured parties. For those who are registered as partially sighted, advice should be sought from an optician or doctor whilst those who are registered as blind should not attempt to drive a mobility scooter.

Users who have been prescribed medication which may cause drowsiness should assess whether the use of a mobility scooter is safe or not and, if in any doubt, they should consult their doctor or medical adviser. Mobility scooters should not be operated by anyone who has consumed alcohol.

The Relync R1 is designed to be driven on footpaths and pavements or on the road if there is no suitable pavement or if there is a need to cross the road. Certain companies and authorities will allow mobility scooters and their users access to trains and buses, providing these vehicles are able to carry a mobility scooter and that they have available space. However, it's strongly suggested not to operate the scooter within any motor vehicles.

Indications for Use

The Relync R1 is a mobility scooter which provides transport for the disabled and the elderly and to be used indoors.

Intended Users

A mobility scooter is a battery-powered three wheeled vehicle intended for use by the disabled, the elderly and those unable to walk any distance unaided in order to allow them independent mobility.

Intended users of the Relync R1 should consider factors such as eyesight, the ability to concentrate and react, balance, the safest and easiest way to get on and off the scooter, posture when seated and the ability to sit in that position for sustained periods of time. Intended users should have an adequate standard of vision in order to see and avoid obstacles and be aware of pedestrians and road users.

The intended user of the Relync R1 is the person driving it for mobility purposes but they may seek assistance for operations such as such as folding and unfolding .

Certification and Compliance

The design of the Relync R1 complies with international safety requirements as follows:

Safety	
Scooter	CE
	Rohs
Charger	CE
	Rohs
Battery	CE
	Rohs
	UN38. 3
	MSDS

Risk Management: ISO 14971

The European Medical Devices Directive of 93/42/EEC classifies the Relync R1 as a Class I device.

II. SAFETY

General



Under no circumstances should this mobility scooter be operated without the user first having read and completely understood this user manual.

Safety highlights



The Relync R1 mobility scooter is intended for use indoors and outdoors on pavements and in other pedestrian areas. It should not be used on public highways. Children under 13 years old are not permitted to operate this scooter.

Caution!

Extra care must be taken when using the Relync R1 mobility scooter in adverse weather conditions such as heavy rain, snow, ice or in strong winds. Care should also be taken to avoid certain surfaces such as sand or loose gravel, as described on Page 18.



No attempt should be made to ascend or descend an incline greater than that specified on Page 13.



Always drive straight up or down the ascent or the descent of an incline. Do not approach the obstacle at an angle.

- Do not turn off the power whilst the scooter is in motion as this will cause it to stop abruptly.
- Whilst seated on the scooter, do not bend sideways as there is a danger that the scooter will tip over. Bending forward whilst seated may cause accidental contact with the throttle lever. To avoid the scooter tipping over, it is essential to maintain the centre of gravity.
- Never use the scooter on an escalator or on steps, use the lift instead.
- Whilst operating the scooter, do not use mobile phones or similar communication devices.
- Whilst driving, do not take your hands or feet off the scooter.
- When the battery is being charged, children should not be allowed to play unsupervised near the scooter.
- The scooter should not be used on the road apart from when it is necessary to cross the road or where there is no pavement. In this case, the user should, at all times, observe all traffic rules and be aware that other traffic may not have clear sight of the scooter and its occupant.
- Never attempt to climb a curb which is higher than the limit specified in the Technical Specification of this manual.
- Do not turn off the power whilst the scooter is in motion as this will cause it to stop abruptly.

Whilst seated on the scooter, do not bend sideways as there is a danger that the scooter will tip over. Bending forward whilst seated may cause accidental contact with the throttle lever. To avoid the scooter tipping over, it is essential to maintain the centre of gravity.

- Never use the scooter on an escalator or on steps, use the lift instead.
- Whilst operating the scooter, do not use mobile phones or similar communication devices.
- Whilst driving, do not take your hands or feet off the scooter.
- When the battery is being charged, children should not be allowed to play unsupervised near the scooter.
- The scooter should not be used on the road apart from when it is necessary to cross the road or where there is no pavement. In this case, the user should, at all times, observe all traffic rules and be aware that other traffic may not have clear sight of the scooter and its occupant.
- Never attempt to climb a curb which is higher than the limit specified in the Technical Specification of this manual.

Modifications

The Relync R1 has been designed to ensure optimum mobility and ease of use and other accessories are available from Relync to enhance its performance as well as the user's comfort. Apart from the addition of these accessories, no part, feature or function of the scooter should be modified, removed or disabled.

Pre-ride Safety Check

In order to become familiar with the scooter and its capabilities, Relync suggests that each time the scooter is used, a safety check is first carried out to ensure its smooth operation. These checks include:

- Correct tyre pressure
- Secure battery connections
- Efficient brake operation
- Fully charged battery
- All folding parts are securely locked

In the event that the safety check highlights a problem, please contact an authorised Relync dealer or the original place of purchase.

Weight Limitations

The Relync R1 has been designed to bear a maximum of 120kg user weight.



WARNING! Do not exceed the weight capacity of 120 kg, doing so will invalidate the warranty. Relync will decline responsibility for any injuries or damage that result from exceeding the specified weight capacity.



WARNING! Never carry passengers on the scooter. This may result in the scooter tipping over as a result of an unstable centre of gravity.

Tyre Inflation

The air pressure of the pneumatic tyres on the rear wheels should be checked weekly. This will help the scooter to run smoothly and also preserve the life of the tyres.



WARNING! It is vital that the pneumatic tyres are kept at a pressure of 30-36 psi. If the tyres are underinflated, control may be lost and if they are overinflated there is a risk that they will burst.



WARNING! Always inflate the pneumatic tyres using a regulated air hose with a pressure gauge to avoid underinflating or overinflating them.



WARNING! If a tyre has a puncture, do not use the scooter. It should be repaired locally by a suitable facility or by a Relync authorised dealer.

Incline

With increasing regulation regarding access for the elderly and disabled, many buildings now feature ramps to facilitate ease and safety of access. Occasionally these ramps feature a 180 degree turn and this will require particular attention to be paid to cornering when using the scooter.

- Approach the downhill part of a ramp with great caution.
- When approaching tight corners, do not try to cut them otherwise you may become stuck or collide with the barriers. Instead, negotiate the corner in a wide arc leaving the scooter plenty of room to turn.
- On the downward part of a ramp, the speed adjustment must be set to the lowest setting for safety and control purposes.
- Always try to avoid stopping or starting suddenly.

When negotiating an incline, it is essential to keep the scooter moving forward. If it is necessary to stop, start off and accelerate slowly. When approaching a decline, the speed adjustment must be set to the lowest setting for safety and control purposes. If the scooter gathers speed too quickly, release the throttle and allow the scooter to come to a halt before carefully re-engaging the throttle to effect a controlled and safe descent.



WARNING! When negotiating an incline, always drive the scooter in a straight line, do not zig-zag or try to drive at an angle. Always be careful when climbing an incline and proceed with caution.



WARNING! Never drive the scooter at an angle across the side of an incline or up and down diagonally. When negotiating an incline, try not to stop if at all possible.



WARNING! If an incline is perceived to be a hazard due to being covered with snow,, ice, damp leaves etc, it should be avoided.



WARNING! Never place the scooter in the freewheel mode when you are either seated or standing by it and are on an incline or decline.



WARNING! Although the Relync R1 mobility scooter can climb slopes exceeding those shown in figure 1, these guidelines and any others referred to in this user manual should be adhered to and not exceeded.

Not all countries have regulations in place that stipulate the requirements for public ramps for handicap access and therefore the gradient of slopes may vary. In addition man-made or naturally occurring slopes will not have been designed with mobility scooters in mind. Figure 1 below shows the stability of the scooter and its capabilities in negotiating gradients with different weight loads during testing. The seat is in its highest and most rearward position which you should use as a guideline. User weight will affect the scooter's ability to negotiate an incline in terms of its speed, setup and angle of approach.



WARNING! The scooter may become unstable and liable to tip if an attempt is made to ascend or descend a gradient steeper than that shown in figure 1.

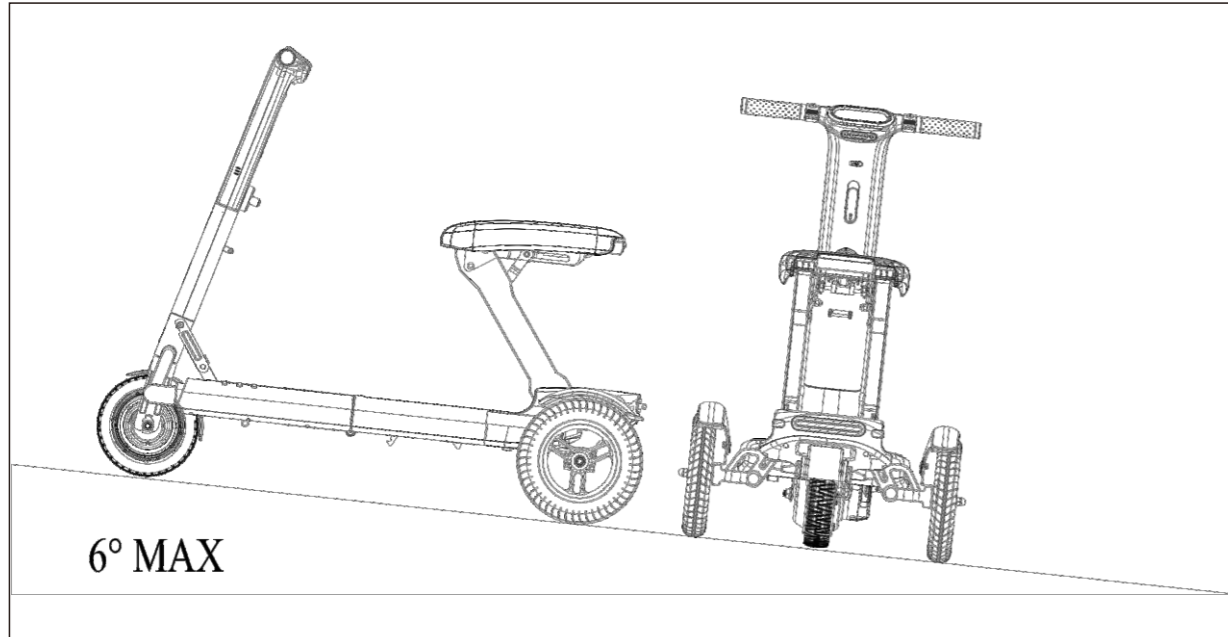

Figure 1. Maximum Recommended Incline Angle

On approaching an incline, it is advisable to lean forward as shown in figures 2A and 2B. The centre of gravity of both yourself and the scooter automatically shift towards the front offering increased stability.

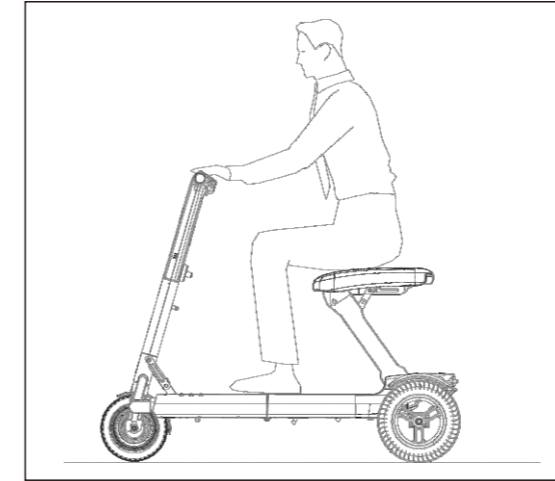

Figure 2A. normal Driving Position

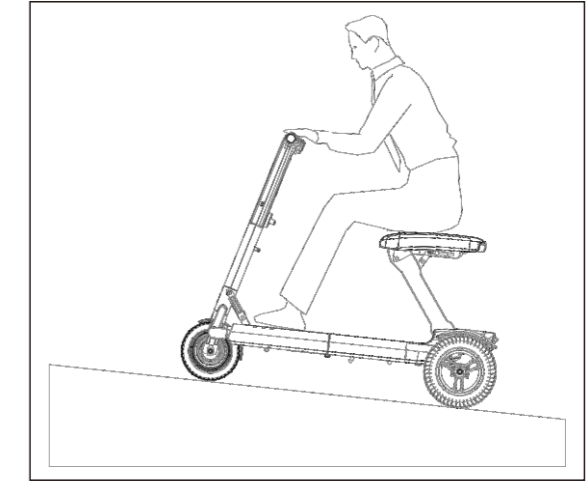

Figure 2B. Shifts Center Of Gravity



Caution! When the throttle lever is released when the scooter is moving forward on a ramp, the scooter is liable to roll back up to one foot until the brake is engaged. When the throttle lever is released when the scooter is reversing, the scooter may roll back up to 3 feet before the brake becomes effective.

Cornering

Using excessive speed when cornering can cause the scooter to become unstable and increase the likelihood of tipping. If you are concerned that the scooter may be about to tip over, immediately reduce speed and lessen the sharpness of the angle of the turn. Apart from excessive speed and the sharpness of the angle of the turn, there are other causes of tipping when cornering which include uneven or inclined roads, sudden changes of direction and passing from one sort of surface to another, i.e. a soft surface such as grass onto a harder paved area.



WARNING! Speed should be reduced and a stable centre of gravity kept when cornering to avoid the risk of tipping. Never corner at high speed or sharply.

Braking

- The Relync R1 features two highly effective braking systems:
- The regenerative brake employs power from the batteries to quickly slow down the vehicle when the throttle lever is placed in the centre or stop position.
- The parking brake is automatically activated after the regenerative brake has slowed the vehicle to a stop or when the power has been disconnected.

Driving Surfaces

When used on normal driving surfaces such as tarmac, concrete etc, the Relync R1 has been engineered to offer maximum stability but its design has been further enhanced to provide similar stability on certain other surfaces such as grass, packed gravel and soil so it can be safely used, for example, on lawns.

- Speed should be reduced when driving on abnormal or uneven surfaces
- The scooter should not be driven through tall grass or other vegetation as there is a risk that this may become entangled around the axle
- The scooter should not be driven on loose gravel or sand
- Do not drive on a surface if you are not fully confident about doing so.

Stationary obstacles (steps, kerbs, etc.)



WARNING! Never drive close too close to an unguarded stationary obstacle such as a kerb, step or staircase.



WARNING! Do not try to ascend or descend a stationary obstacle that is higher than 20mm.



WARNING! To avoid the risk of tipping, never drive backwards down a kerb or step.



WARNING! When ascending or descending a kerb or step, always ensure that the scooter approaches at a straight direct angle as shown .

Inclement Weather Precautions

The scooter should not be exposed to inclement weather conditions wherever possible. If it begins to rain or snow or if the weather becomes either severely hot or cold, shelter should be sought as soon as possible. If the scooter becomes wet, it should be thoroughly dried before being used again or stored.



WARNING! If the scooter is exposed to rain, snow, road spray or ice or has been driven on wet or icy surfaces, it should be dried and cleaned as soon as possible to avoid damage, in particular to the electrical system.



WARNING! If the scooter is exposed to conditions of extreme heat or extreme cold, this will affect its temperature and there is a risk that damage to the skin may occur if the scooter is touched. It is advisable to use caution when the scooter is used in extremely hot or cold weather or if the scooter has been placed in direct sunlight for sustained periods.

Freewheel Mode

The ReLync R1 features a freewheel lever which is manually operated. The lever should be pushed forward to allow the scooter to be rolled manually. More information regarding the freewheel mode can be found in Section V Operating the Freewheel Mode on page 43.

- Before driving, always ensure that the scooter is not in freewheel mode and that the front wheel is engaged.
- Always ensure that you are aware if the scooter is in driving mode with the front wheel locked or in freewheel mode with the front wheel unlocked. For further instructions see the SAFETY SYMBOLS on page 16 .
- When transporting the scooter, the front wheel must be locked. It must not be left unlocked in the freewheel mode. For further instructions see the Freewheel section on page 43.
- Never sit on the scooter when it is in freewheel mode.

Batteries and Charger

- When the scooter batteries are being charged, children should not be allowed to play unsupervised near the vehicle.
- Do not attempt to charge a battery which has become frozen.
- If a battery becomes damaged, cracked or has been tampered with, place it in a plastic bag and refer to an authorised ReLync dealer for instructions for its disposal.
- The DC cables should be protected from damage.
- An extension cable should not be connected to the battery charger.
- Original ReLync Li-Ion batteries should always be used on the ReLync R1 scooter.

Motor Vehicle Transport

When travelling in a car or van, the scooter should be folded and securely stowed with the batteries removed. Do not attempt to travel in a motor vehicle whilst seated on the scooter.



WARNING! When the scooter is in a moving vehicle, the user should not remain seated on it.



WARNING! When being transported, the scooter and batteries should be fully secured and the batteries kept upright at all times with caps placed on the terminals. No other flammable/combustible objects should be transported with the batteries.

Medical Conditions

- Do not operate the scooter if alcohol has been consumed.
- Do not operate the scooter if you feel dizzy, drowsy, have blurred vision or are unable to operate the scooter safely as a result of a medical condition or medication that you are taking.
- If you have been prescribed medication or have been diagnosed as having physical limitations, ask your doctor if your ability to operate the scooter safely will be impaired.

Product Safety Symbols

Symbols have been placed on the scooter which the user should read, understand and become familiar with. These relate to warnings and actions which are either necessary or prohibited.

Locked padlock indicates Drive Mode. Unlocked padlock indicates Freewheel Mode



Do not sit when in freewheel mode



For Indoor Use



Not Intended for use
in motor vehicle



Do not stand when
driving scooter

Max. user weight: 120KG
Driving Restrictions: See warnings in user manual

Model Weight: 27KG

Refer to the User Manual for information regarding the maximum user weight of 120kg.

Avoid resting your feet or putting your feet through the groove of the scooter.

! WARNING

**DO NOT REST YOUR FEET IN THE GROOVE
DO NOT PUT YOUR FEET THROUGH**

FOR YOUR SAFETY:

Reduce speed to minimum when approaching incline or a turn.



Avoid ascending or descending ramps, curbs or slopes greater than 6°.



Avoid sharp turns or sudden stops.





Do not pull handle while seated

The handle should not be lifted while seated



Do not lift handle while seated

The handle should not be pulled while seated



Pinch Point

Avoid placing your hands or fingers near pinch points.



Pinch Point



WARNING! It is essential that you read the following information regarding electromagnetic interference and its effects on the scooter.

EMI

Electromagnetic Interference (EMI) from radio wave sources

Radio and TV stations and transmitters and communication devices such as mobile phones and two way radios may emit electromagnetic energy which could interfere with the scooter causing it to move by itself or in an unintentional direction or for the brakes to be released. EMI (Electromagnetic Interference), which is measured in volts per metre, may also damage the scooter's control system.

The Relync R1 has the ability to resist an EMI of up to 20 volts per metre which will provide adequate protection from most common sources of EMI.

In normal daily life, some sources of fairly intense EMI may be encountered, some of which can be easily avoided while others are not so obvious and exposure to them may be unavoidable. The list below provides information about three sources of EMI.

1) Devices such as mobile phones, transceivers used by security and the emergency services, CB radios, walkie-talkies and other hand-held transceivers with an antenna directly affixed to the transmitting unit are defined as handheld portable transceivers

Note: Some of these devices, particularly mobile phones, may continue to transmit signals when not in use.

2) Transceivers with an antenna affixed to the vehicle on the outside, i.e. the roof, such as those used by the emergency services and taxis are defined as medium range mobile devices.
3) Broadcast transmitters such as radio and TV tower and amateur radios are defined as long range devices.

Note: EMI which affects your scooter is not likely to be caused by other types of portable devices such as hairdryers, laptop computers, televisions, CD players, shavers, etc



WARNING! Please be aware that when in use the mobility scooter may affect certain devices within its vicinity due to the emission of EMI, for example shop security alarms and automatic doors.

Note: No hazardous radiation is generated by the Relync R1 Mobility Scooter.

III. PRODUCT DESCRIPTION

Basic Principle

Relync R1 is a three-wheeled powered vehicle driven by either one or two batteries, and controlled by an electronic system. Users can operate the scooter via its own control system.

Dimensions

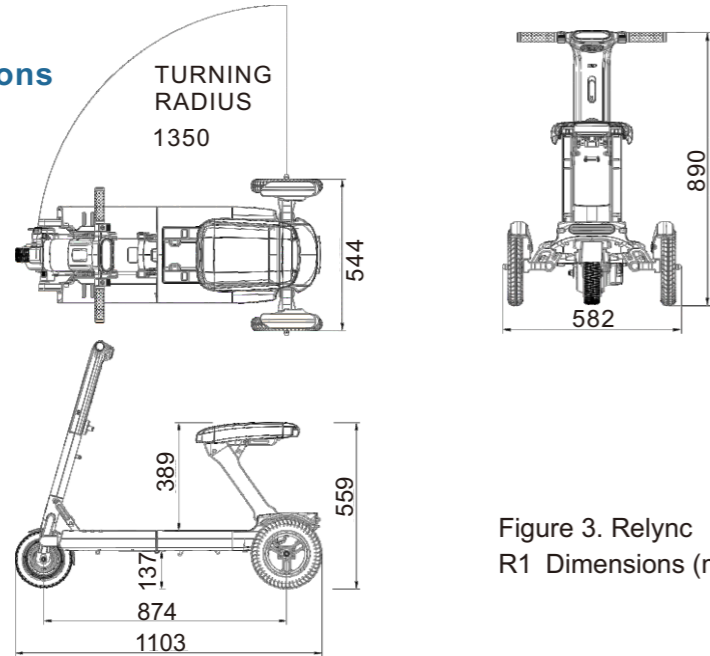

Figure 3. Relync R1 Dimensions (mm)

Specifications

The Relync R1 mobility scooter is powered by batteries and is controlled by an electronic system.

Model Name	Relync R1
Model No.	RAA
Weight	Main body:26kg+Backrest:1kg+Each battery:1.3kg
Maximum Speed	4 mph(6.4km/h)
Maximum User Weight	18st. (120kg)
Endurance Range	1 battery: up to 9 miles (15km); 2 batteries: up to 18 miles (30km)
Battery Capacity Output	36V 400Wh Lithium battery
Charger	UL and CE approved, 110-240V
Charging Time	1 battery: 4 hours 2 batteries: 6 hours
Motor Type	BLDC (Gear motor)
Power of Motor	170w

Braking System	Electromagnetic brake
Body Material	Aviation-grade aluminum, high-tech plastics, nylon-enforced ABS
Maximum Incline	6 degree
Turning Radius	1350 mm
Tyre Type	Solid front tyre; Pneumatic rear tyres
Tyre Dimensions	8" front tyre; 10" rear tyre
Unfolded Size (Riding Mode)	1090*550*890mm (L x W x H)
Folded Size (Folding Mode)	600*550*280mm (L x W x H)
Folded Size (Trolley Mode)	940*550*280mm (L x W x H)
Backrest	Included
Flammability	UI91 V-0

IV. YOUR RELYNC R1

Driving Console

The scooter's driving console, or dashboard, features the controls and displays necessary for safe operation when in use.

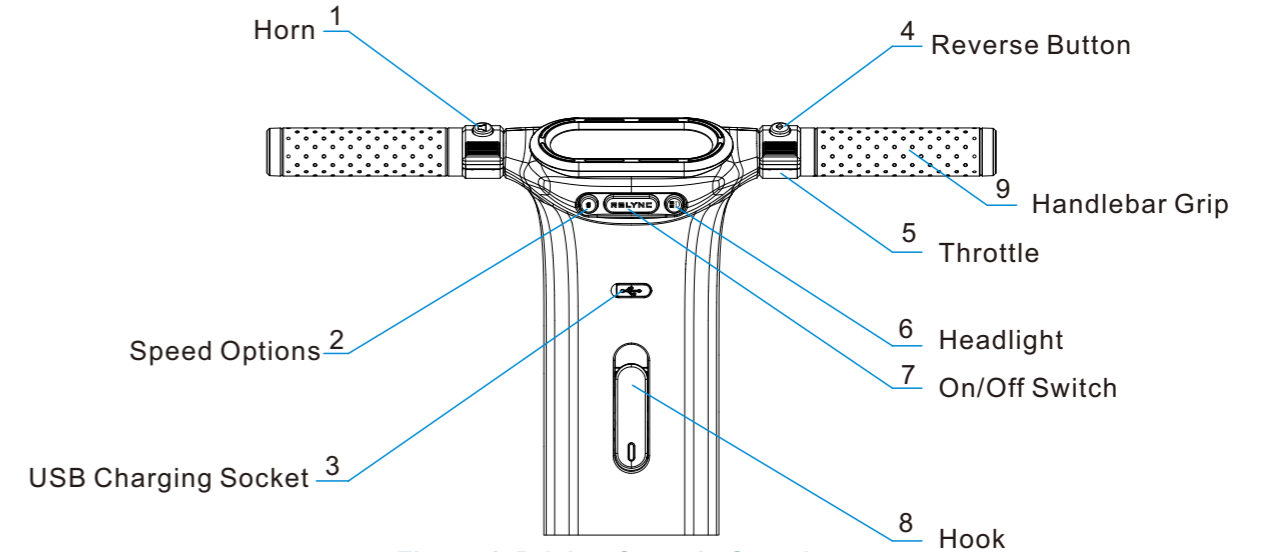

Figure 4. Driving Console Overview

If you would prefer the throttle lever to be positioned on the left rather than on the right, please contact an authorised Relync dealer.



WARNING! The weight capacity of the hook is 2kg.

Display

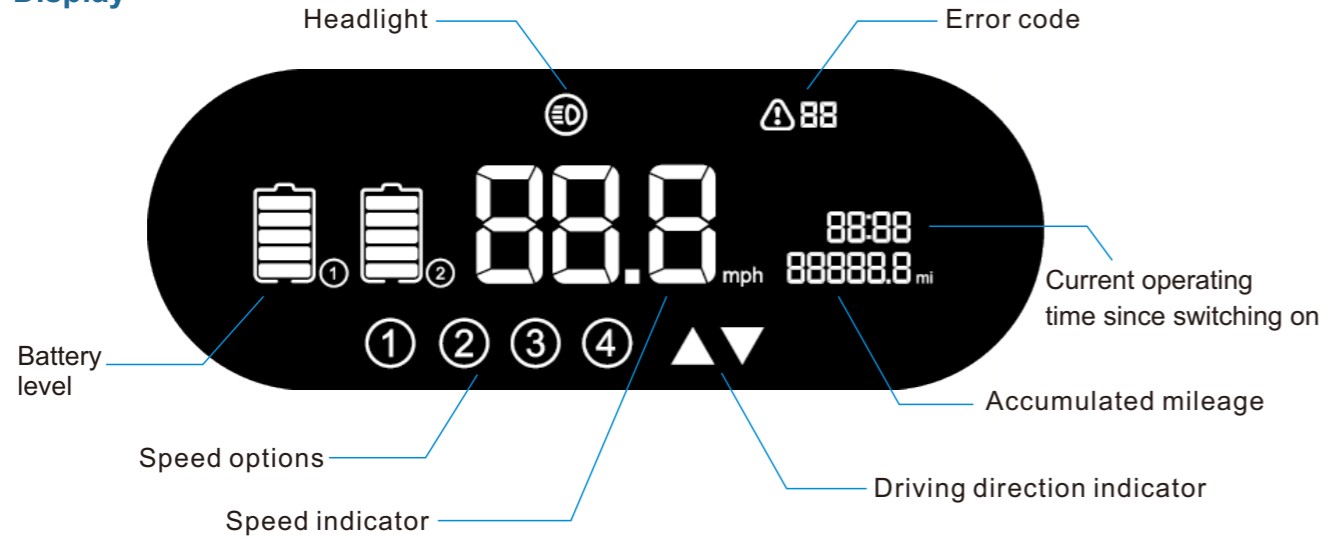

Figure 5. Dashboard

Scooter

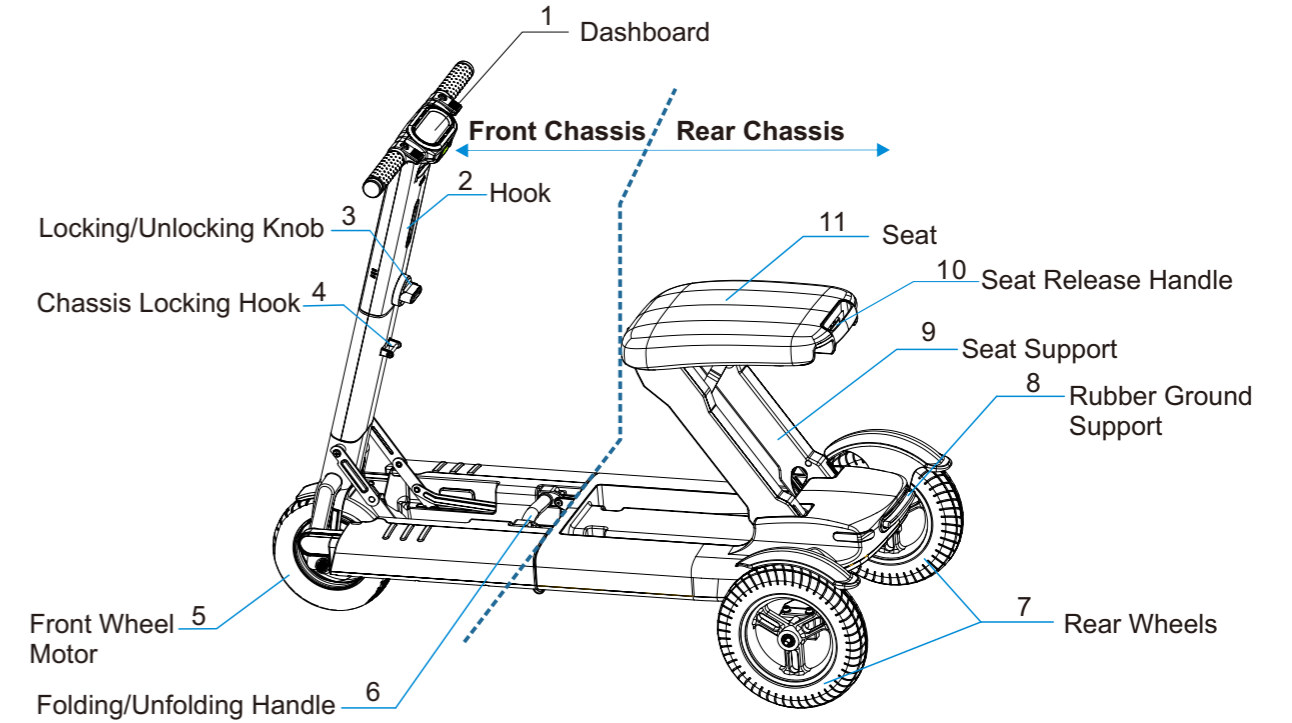

Figure 6. Relync Scooter Parts

V. OPERATION

Unfolding Your Relync R1

1. Before unfolding your Relync R1 mobility scooter, please ensure that it is on level ground with a clearance of at least 2 meters around the wheels.



Figure 7

2. Grip the handlebar at the bottom of the folded scooter with your left hand and raise until upright and in line with the body of the scooter.



Figure 8

3. Rotate the locking knob clockwise until you hear a "click". Continue to rotate the knob to make sure that it is securely locked and can turn no further.

Attention! Ensure that the locking knob has been fully turned before proceeding to the next step.

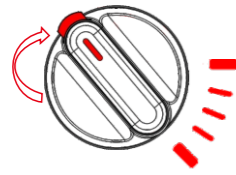

Unlocked Position

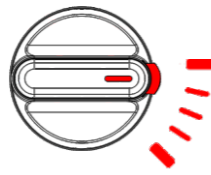

Locking "click"

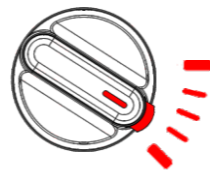

Locked Position

Figure 9

4. Hold the black handle with your right hand and press the unfold button with your thumb. At the same time, hold the handlebar with your left hand until the front chassis and the rear chassis separate. Release the unfold button so that the front chassis can extend and the front wheel smoothly touches the ground.



Figure 10



Caution! To prevent the R1 from moving during unfolding, place one foot against one of the rear wheels until the front and rear wheels are apart and the scooter has been unfolded.

Caution: The scooter will tilt forward after it has been unfolded.

5. Press the black handle flat into the slot.



Figure 11

 **Warning!** Always ensure that the black handle is in place in the slot before driving.

6. Pull the seat handle up until you hear a “click”.



Figure 12

 **Warning!** Always use your palm to press the seat down to check that it is stable before driving.

Folding Your Relync R1

1. Make sure that there are no obstacles close to the scooter before operating the seat release handle and putting the seat down.



Figure 13

 **Warning!** To avoid pinch points and possible injury, do not put your hands or fingers in places other than those shown in the picture above.

Warning! Do not operate the seat release handle if someone is seated on the scooter.

2. Raise the black handle and the scooter chassis at the same time.



Figure 14 ▶

3. The Relync R1 has been designed to use two folding hooks. The first “click” indicates that the front chassis and the rear chassis are locked together.

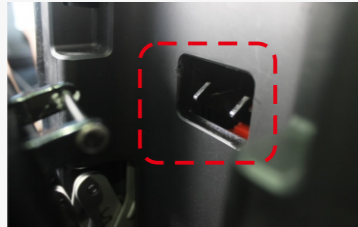

Figure 15 ▲

Important! Ensure that the chassis of the scooter remains upright throughout the folding process.



Figure 16 ▶

4. A second “click” indicates that the scooter head is locked within the chassis.



Figure 17 ▶

Note: The scooter can be wheeled around like a trolley.

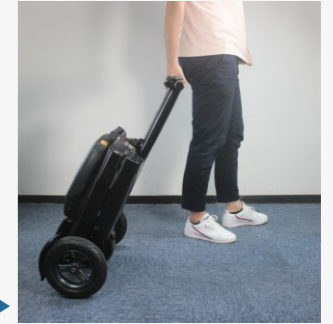

Figure 18 ▶

5. Press the red safety lock button and rotate the locking knob anticlockwise to unlock the head of the scooter.



Figure 19

Getting on Relync R1

- Check that the scooter is switched off
- Check that the scooter is opened fully and securely (more information can be found in this User Manual under the Unfolding section)
- Place one foot on the middle of the deck and sit on the seat making sure you are comfortable and secure



WARNING! Avoid leaning on the handlebar tiller when getting on or off the scooter. It may accidentally move causing you to lose balance and fall.



WARNING! Do not use the seat or backrest for support when getting on or off the scooter. The seat may accidentally fold down causing you to lose balance and fall.



WARNING! Before getting onto the scooter, ensure that all parts are securely locked in place.

Getting off Relync R1

- Check that the power is switched off
- Place one foot on the ground, move your weight onto that leg and slowly stand up, bringing your other leg to the ground
- Move away from the scooter

Driving

Prior to using the mobility scooter:

1. Check that the batteries are securely locked in place within the housing.
2. Check that the batteries have been fully charged or that they will have enough capacity for your journey.
3. Check that the freewheel lever is in the locked position.
4. Check that all locking parts are in the appropriate position, fully open and locked.

Switching on Relync R1

To switch the scooter on, press the Relync button and hold it down for 2 seconds.

The lights will come on for one second. The following information will then be displayed:

- Battery level
- Speed
- Direction arrow indicating forward mode
- Operating time
- Accumulated mileage

Forward Driving

- With your hands on the handgrips, move the tiller to the central position to drive forward
- Check which drive mode you are in by looking at the direction arrow on the dashboard. For forward mode, the arrow should be pointing forwards away from your body. If it is facing backwards, depress

The direction button until you hear a beep and the arrow is facing forward.

- To operate the throttle and move forward, use your right thumb to operate the throttle lever.
- To accelerate, press the speed button.
- To bring the Relync R1 to a stop, take your thumb off the throttle. It will automatically return to the off position and the scooter will slowly stop.

The Relync R1 should always be brought to a complete stop before any change of direction, i.e. from forward mode to reverse mode or from reverse mode to forward mode.

In order to maintain full control, extra care and a reduction in maximum speed should be employed when using the scooter in crowded areas or close to obstacles and hazards.

Reverse Driving

- With your hands on the handgrips and using one of the fingers of your right hand, depress the direction button on top of the throttle to change from forward mode to reverse mode.
- To operate the throttle and move backwards, use your right thumb to press the throttle lightly.
- Reversing beeps will confirm that the scooter is now in reverse mode.
- To bring the Relync R1 to a stop, take your thumb off the throttle. It will automatically return to the off position and the scooter will slowly stop.
- Please be aware that, for safety reasons, the speed in reverse will be slower than the maximum speed that has been set on the control.

Stopping

To bring the scooter to a halt, simply release the throttle. The throttle will automatically return to the off position which will cause the regenerative brakes to operate. The scooter's mechanical brake will then place the scooter into park mode.

Emergency Braking

If you have to stop in an emergency and releasing the throttle does not bring the scooter to a halt, use the RELYNC on/off switch to turn the scooter off and bring it to a stop.

Steering

- The Relync R1 mobility scooter is very easy to steer.
- Place both hands on the handgrips, turn the tiller to the left or the right according to which direction you wish to go.
- Always ensure that there is enough clearance around the scooter to avoid the rear wheels coming into contact with any obstacles.

If negotiating a tight spot is unavoidable, for example going through a door or gate way, follow these instructions:

- Bring the scooter to a halt
- Check that the speed is set to the slowest setting on the control
- Adjust the direction of the tiller to where you want to go
- Use your right thumb to press the throttle lightly and slowly turn the scooter

Operating the Freewheel Mode

If the batteries on the Relync R1 die or the scooter fails to operate correctly, it can be moved manually by switching the freewheel lever on the front wheel.



Figure 20. Releasing the Freewheel

Ensure that the freewheel lever is pushed back before operating the scooter again.



Figure 21. Securing the Freewheel

Batteries and Charger

The charger supplied with the Relync R1 scooter is fully approved and small but powerful. It can be connected to any electrical grid rating of 110VAc-240VA.

- To connect the charger correctly, connect the DC cable to the battery charger plug and then connect the charger's AC cable to the electrical socket.
- To disconnect the charger correctly, apply the steps for connecting the charger in reverse.



Figure 22. Relync R1's Li-ion Battery



Figure 23. Relync R1's Charger

Installing and Removing the Batteries

1.This is the battery housing.



Figure 24

2.Pull the tab on the battery housing upwards to open it.



Figure 25

3.Hook your finger through the metal handle on top of the battery to remove it from the housing.



Figure 26

4.After removing the battery, press the cover of the housing back down until you hear a "click".



Attention! Batteries are both removed and installed in the same way.



Figure 27

Charging the Batteries

On the front chassis of the scooter there is a DC port to which the charger can be connected in order to charge the batteries without removing them from the scooter.



Figure 28

Charging Indication

The battery capacity indicator on the dashboard displays the charge level of the batteries during charging. Once fully charged, this information will no longer be displayed.

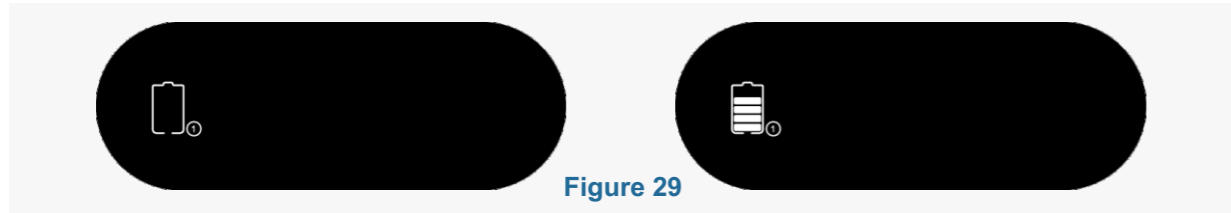

Figure 29



WARNING!

- Do not attach cables to the battery terminals in an attempt to charge the batteries.
- When the scooter is in use, do not attempt to charge the batteries.
- If any part of the scooter is wet or damp, do not attempt to charge the batteries.
- If the scooter is outside, do not attempt to charge the batteries.
- While the batteries are on charge, do not sit on the scooter.
- If the batteries are going to be stored for a long period, they should be fully charged beforehand and recharged every 6 months after.
- Chargers approved by Relync should always be used.
- If an extension cable is used for the charger, there may be a risk of electrical shock or fire.

VI.TROUBLESHOOTING RELYNC R1

If the scooter fails to turn on

1. If the scooter turns off immediately after being switched on, check that the freewheel lever is in the correct position.
2. Check that the charger is not still connected to the batteries.
3. Check if the batteries are charged by connecting them to the charger. The display will indicate if they are charged or empty.
4. If the batteries are charged, check that they are secure in the housing and that no foreign bodies or dirt are preventing contact between a battery and a connection.
5. Press the RELYNC On/Off button for at least two seconds to try to switch the scooter on. If this fails to work, contact a Relync authorised dealer.

If the scooter is switched on but fails to move

Begin by checking the position of the freewheel lever and ensure that it is in the locked position as pictured in the Product Safety Symbols section.

Problems with battery charging

If the batteries do not charge within a period of 12 hours:

- Check the connections on the batteries

- It may prove necessary for the batteries to be checked and possibly replaced which can be done through an authorised Relync dealer.
- Arrange for the charger to be tested



WARNING! Avoid allowing the battery packs or charger to be plugged in for more than 12 hours. The battery packs may become damaged.

Error Codes

The Relync R1 features a smart control which will display 2 digit numbers on the dashboard if a problem is detected. Some error codes simply alert you to the fact that the scooter is due to be serviced and will not affect the use of the scooter while other error codes may indicate a problem serious enough to prevent the use of the scooter for safety reasons. Inform the authorised Relync dealer where you purchased the scooter. (Please refer to the Display section in this User Manual on page 29)

VII.MAINTENANCE

The expected service life of the Relync R1 mobility scooter is 7 years although this can be prolonged for a much longer period if appropriate care and maintenance are applied.

The maintenance procedures should be followed at least once a year or sooner if necessary.

Relync and its authorised dealers and technicians can supply replacement parts.

Wheels and Tyres

The front wheel of the Relync R1 is a solid tyre. This means that, rather than being filled with air, it is filled with foam so, even if the tyre is punctured, it will never be flat.

The rear wheels of the scooter are fitted with pneumatic tyres whose pressure and condition should be checked prior to the scooter being used. The correct tyre pressure should be maintained at all times and the tyres should be checked frequently for wear and tear.

If the solid or pneumatic tyres need to be replaced due to damage, an authorised Relync dealer will be able to assist.

Batteries and Charging

The Relync R1 battery is small but powerful and should always be handled with caution. Burns and injuries may be caused if the terminals short out which may also cause damage to the scooter and its electronic system

- The batteries supplied with your scooter are Li-ion batteries which are maintenance free
- This type of battery does not have a 'memory', there is no need to fully discharge the batteries before charging them again.
- If you do not intend to use the Relync R1 scooter for a prolonged period, the batteries should be charged to 60% capacity before the scooter and batteries are stored away. If they are charged to 60% and kept at a room temperature of 22°C, the batteries can be left for up to 6 months without further attention.
- If the scooter has not been used for over a month, ensure that the batteries are placed on charge the

night before you intend to use the scooter again so that the batteries are fully charged.

- The batteries are sealed units so are safe to transport on planes and public transport with no risk of spills or leaks.
- If you follow the guidelines within this User Manual, the life of your batteries will be extended.
- Should the terminals on the scooter become corroded or damaged, they must be cleaned or repaired by a certified Relync technician.
- If the terminals on a battery become corroded then the battery must be replaced.



FIRE HAZARD! When charging the batteries, under no circumstances cover either the charger or its ventilation slot and always ensure that the battery charger is used in well ventilated spaces.

Cleaning, Body Care.

The body of the Relync R1 scooter is made up of ABS parts. ABS is a durable pre-painted plastic. Its high gloss can be maintained by regular cleaning with a clean damp cloth.

Storage

If you do not plan to use the scooter for any prolonged period, it is advisable to:

- Remove the batteries from their housing.
- Store the scooter in a dry environment at room temperature.
- Store the scooter away from anywhere that is subject to extremes of temperature.



WARNING! Batteries should be protected from temperatures below freezing and a battery that has become frozen should not be charged to avoid damage or injury.

Note: Please refer to the Operation section on Page 36 for details of how to fold and store your Relync R1 scooter.

After a prolonged period of storage, to begin using the scooter again:

- If it was closed or folded during storage, open the scooter.
- Check the scooter for obvious damage such as corrosion or breakages and that all moving parts are as they should be. If this is not the case, contact an authorised Relync dealer.
- Install the batteries and switch the scooter on
- Check that all control buttons and levers and the dashboard display are working correctly and, if not, contact a Relync authorised dealer.

Disposal

Should you wish to dispose of your scooter, this must be done following local and national regulations. Further information regarding proper disposal can be obtained from your local waste disposal agency or an authorised Relync dealer.

VIII.LIMITED WARRANTY

The Two Year Limited Warranty Covers:

Structural frame components including the chassis, steering mechanism, seat mechanism and frame welding.

One Year Limited Warranty

Drivetrain components including the brakes, motor and front wheel fork.

In addition, all electronic parts including the battery charger and controller are covered by the one year limited warranty. Any servicing or repair work required on the control system or battery charger must be undertaken by an authorised Relync dealer or technician. If any attempt has been made to open, tamper with or dismantle any of these items, this guarantee will be invalidated.

Batteries

The batteries supplied for the Relync R1 mobility scooter are covered by a 12 month warranty from the date of purchase by the original battery manufacturer. Gradual deterioration in battery performance caused by not following the usage instructions specified in this User Manual or wear and tear caused by excessive use are not covered.

Items Not Covered By Warranty

This warranty does not cover any items which are deemed to require replacement as a result of normal wear and tear. This includes:

- Tyres
- LED lights
- Upholstery
- Damage caused to the scooter by accident or misuse for which Relync cannot be held responsible

The warranty will not cover:

- Labour, telephone call costs, shipping and other costs incurred in the repair of the product

In addition, the warranty will not apply if:

- The serial number has been removed or defaced
- The circumstances are beyond the control of Relync

Service Checks and Warranty Service

Please contact the authorised Relync dealer where the scooter was purchased for advice and information regarding service checks and warranty servicing

Replacement Units

Replacement units may be supplied at the discretion of the Relync provider and are not the responsibility of the manufacturer. Please contact your authorised Relync dealer for further information.

IX. TRANSPORTING

The Relync R1 mobility scooter can easily be transported by land, sea or air although federal regulations and airline policies will apply for plane transport. It is always advisable to consult your carrier beforehand to check that both the scooter and the lithium-ion batteries will be permitted.

When transporting the Relync R1 mobility scooter:

- Remove the batteries and store in a safe place
- Make sure the scooter is fully closed.

Note: Please refer to the Operation section on Page 36 for information regarding folding your Relync R1 scooter for transport.

- Ensure that the scooter is secured safely so that it will not move around or vibrate and cause or suffer damage.
- Make sure that no one sits on the scooter if it is to be transported in a vehicle while fully assembled and in the open rather than folded position.
- When an external lifting system is being used, the scooter should be safely secured to the lift to prevent it falling.
- Ensure that the specifications regarding temperature and humidity are met when the scooter is being transported.



X. CONTACT INFORMATION

Updated information on Relync scooter can be found on the website:
www.relync.com



Legal Manufacturer

Address:

RELYNC TECH LTD.

5B01, 11 Building, The capital of the design, TianMian Village, HuaFu Str,
 FuTian District, ShenZhen City, GuangDong Province, China

Email: contact@relync.com

EC	REP
----	-----

Authorized representative

MedNet GmbH

Borkstrasse 10, 48163 Münster, Germany

